

Chapter 5

THE APPLICATION OF THE Z TRANSFORM

5.1 Introduction

5.2 The Discrete-Time Transfer Function

Copyright © 2005- Andreas Antoniou
Victoria, BC, Canada
Email: aantoniou@ieee.org

September 5, 2008

Introduction

- ▶ Through the use of the z transform, a discrete-time system can be characterized by a discrete-time transfer function.

Introduction

- ▶ Through the use of the z transform, a discrete-time system can be characterized by a discrete-time transfer function.
- ▶ The discrete-time transfer function plays the same key role as the continuous-time transfer function in an analog system.

Introduction

- ▶ Through the use of the z transform, a discrete-time system can be characterized by a discrete-time transfer function.
- ▶ The discrete-time transfer function plays the same key role as the continuous-time transfer function in an analog system.
- ▶ It can be used to obtain the time-domain response of a system to any excitation or its frequency-domain response.

Introduction

- ▶ Through the use of the z transform, a discrete-time system can be characterized by a discrete-time transfer function.
- ▶ The discrete-time transfer function plays the same key role as the continuous-time transfer function in an analog system.
- ▶ It can be used to obtain the time-domain response of a system to any excitation or its frequency-domain response.
- ▶ In this presentation, the definition, derivation, and properties of the discrete-time transfer function are examined.

Discrete-Time Transfer Function

- ▶ The transfer function of a discrete-time system is the *ratio of the z transforms of the response and the excitation.*

Discrete-Time Transfer Function

- ▶ The transfer function of a discrete-time system is the *ratio of the z transforms of the response and the excitation.*
- ▶ Consider a linear time-invariant discrete-time system and let
 - $x(nT)$ be the excitation (or input)
 - $y(nT)$ be the response (or output)
 - $h(nT)$ be the impulse response

- ▶ The convolution summation gives

$$y(nT) = \sum_{k=-\infty}^{\infty} x(kT)h(nT - kT)$$

- ▶ The convolution summation gives

$$y(nT) = \sum_{k=-\infty}^{\infty} x(kT)h(nT - kT)$$

- ▶ From the real-convolution theorem (see Chap. 3), we have

$$\mathcal{Z}y(nT) = \mathcal{Z}x(nT)\mathcal{Z}h(nT)$$

- ▶ The convolution summation gives

$$y(nT) = \sum_{k=-\infty}^{\infty} x(kT)h(nT - kT)$$

- ▶ From the real-convolution theorem (see Chap. 3), we have

$$\mathcal{Z}y(nT) = \mathcal{Z}x(nT)\mathcal{Z}h(nT)$$

- ▶ Therefore,

$$\frac{Y(z)}{X(z)} = H(z)$$

In effect, *the transfer function is also the z transform of the impulse response of the system.*

Derivation of Transfer Function from Difference Eqn.

- ▶ A noncausal, linear, time-invariant, recursive discrete-time system can be represented by the difference equation

$$y(nT) = \sum_{i=-M}^N a_i x(nT - iT) - \sum_{i=1}^N b_i y(nT - iT)$$

where M and N are positive integers.

Derivation of Transfer Function from Difference Eqn.

- ▶ A noncausal, linear, time-invariant, recursive discrete-time system can be represented by the difference equation

$$y(nT) = \sum_{i=-M}^N a_i x(nT - iT) - \sum_{i=1}^N b_i y(nT - iT)$$

where M and N are positive integers.

- ▶ The z transform gives

$$Y(z) = \mathcal{Z}y(nT) = \mathcal{Z} \sum_{i=-M}^N a_i x(nT - iT) - \mathcal{Z} \sum_{i=1}^N b_i y(nT - iT)$$

Transfer Function from Difference Equation *Cont'd*

• • •

$$Y(z) = \mathcal{Z} \sum_{i=-M}^N a_i x(nT - iT) - \mathcal{Z} \sum_{i=1}^N b_i y(nT - iT)$$

Using the *linearity and time-shifting theorems* of the z transform, we get

$$\begin{aligned} Y(z) &= \sum_{i=-M}^N a_i z^{-i} \mathcal{Z} x(nT) - \sum_{i=1}^N b_i z^{-i} \mathcal{Z} y(nT) \\ &= \sum_{i=-M}^N a_i z^{-i} X(z) - \sum_{i=1}^N b_i z^{-i} Y(z) \end{aligned}$$

Transfer Function from Difference Equation *Cont'd*

• • •

$$Y(z) = \sum_{i=-M}^N a_i z^{-i} X(z) - \sum_{i=1}^N b_i z^{-i} Y(z)$$

Solving for $Y(z)/X(z)$ and then multiplying the numerator and denominator polynomials by z^N , we get

$$\begin{aligned} H(z) &= \frac{Y(z)}{X(z)} = \frac{\sum_{i=-M}^N a_i z^{-i}}{1 + \sum_{i=1}^N b_i z^{-i}} = \frac{\sum_{i=-M}^N a_i z^{N-i}}{z^N + \sum_{i=1}^N b_i z^{N-i}} \\ &= \frac{a_{(-M)} z^{M+N} + a_{(-M+1)} z^{M+N-1} + \dots + a_N}{z^N + b_1 z^{N-1} + \dots + b_N} \end{aligned}$$

Transfer Function from Difference Equation *Cont'd*

• • •

$$H(z) = \frac{a_{(-M)}z^{M+N} + a_{(-M+1)}z^{M+N-1} + \dots + a_N}{z^N + b_1z^{N-1} + \dots + b_N}$$

If $M = N = 2$, we have

$$H(z) = \frac{N(z)}{D(z)} = \frac{a_{(-2)}z^4 + a_{(-1)}z^3 + a_0z^2 + a_1z + a_2}{z^2 + b_1z + b_2}$$

Transfer Function from Difference Equation *Cont'd*

• • •

$$H(z) = \frac{a_{(-M)}z^{M+N} + a_{(-M+1)}z^{M+N-1} + \dots + a_N}{z^N + b_1z^{N-1} + \dots + b_N}$$

If $M = N = 2$, we have

$$H(z) = \frac{N(z)}{D(z)} = \frac{a_{(-2)}z^4 + a_{(-1)}z^3 + a_0z^2 + a_1z + a_2}{z^2 + b_1z + b_2}$$

Note: In noncausal systems, the degree of the numerator polynomial exceeds the degree of the denominator polynomial.

Transfer Function from Difference Equation *Cont'd*

- ▶ For a causal system, $M = 0$ and hence

$$\begin{aligned} H(z) &= \frac{a_{(-M)}z^{M+N} + a_{(-M+1)}z^{M+N-1} + \dots + a_N}{z^N + b_1z^{N-1} + \dots + b_N} \\ &= \frac{a_0z^N + a_1z^{N-1} + \dots + a_N}{z^N + b_1z^{N-1} + \dots + b_N} \end{aligned}$$

Transfer Function from Difference Equation *Cont'd*

- ▶ For a causal system, $M = 0$ and hence

$$\begin{aligned} H(z) &= \frac{a_{(-M)}z^{M+N} + a_{(-M+1)}z^{M+N-1} + \dots + a_N}{z^N + b_1z^{N-1} + \dots + b_N} \\ &= \frac{a_0z^N + a_1z^{N-1} + \dots + a_N}{z^N + b_1z^{N-1} + \dots + b_N} \end{aligned}$$

- ▶ Since some of the numerator coefficients can be zero, we conclude that *in causal recursive systems the numerator degree is equal to or less than the denominator degree.*

Representation by Zero-Pole Plots

- By factorizing the numerator and denominator polynomials, the transfer function of a noncausal system can be expressed as

$$H(z) = \frac{N(z)}{D(z)} = \frac{H_0 \prod_{i=1}^Z (z - z_i)^{m_i}}{\prod_{i=1}^P (z - p_i)^{n_i}}$$

where

- z_1, z_2, \dots, z_Z are the zeros of $H(z)$
- p_1, p_2, \dots, p_P are the poles of $H(z)$
- m_i is the order of zero z_i
- n_i is the order of pole p_i
- $M + N = \sum_{i=1}^Z m_i$ is the order of $N(z)$
- $N = \sum_{i=1}^P n_i$ is the order of $D(z)$
- H_0 is a multiplier constant

Representation by Zero-Pole Plots *Cont'd*

• • •

$$H(z) = \frac{N(z)}{D(z)} = \frac{H_0 \prod_{i=1}^Z (z - z_i)^{m_i}}{\prod_{i=1}^P (z - p_i)^{n_i}}$$

- ▶ The order of a discrete-time transfer function is the *order of $N(z)$ or $D(z)$, whichever is larger*, i.e., $M + N$ if $M > 0$ or N if $M = 0$.

Representation by Zero-Pole Plots *Cont'd*

• • •

$$H(z) = \frac{N(z)}{D(z)} = \frac{H_0 \prod_{i=1}^Z (z - z_i)^{m_i}}{\prod_{i=1}^P (z - p_i)^{n_i}}$$

- ▶ The order of a discrete-time transfer function is the *order of $N(z)$ or $D(z)$, whichever is larger*, i.e., $M + N$ if $M > 0$ or N if $M = 0$.
- ▶ Discrete-time systems can be represented by zero-pole plots.

Representation by Zero-Pole Plots *Cont'd*

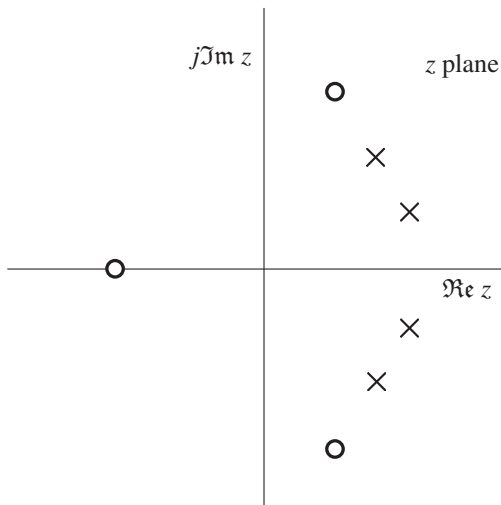

Transfer Function in Nonrecursive Systems

- ▶ A nonrecursive system can be represented by the difference equation

$$y(nT) = \sum_{i=0}^N a_i x(nT - iT)$$

Transfer Function in Nonrecursive Systems

- ▶ A nonrecursive system can be represented by the difference equation

$$y(nT) = \sum_{i=0}^N a_i x(nT - iT)$$

- ▶ Hence the transfer function assumes the form

$$\begin{aligned} \frac{Y(z)}{X(z)} = H(z) &= \sum_{i=0}^N a_i z^{-i} \\ &= \frac{\sum_{i=0}^N a_i z^{N-i}}{z^N} \end{aligned}$$

Transfer Function in Nonrecursive Systems

- ▶ A nonrecursive system can be represented by the difference equation

$$y(nT) = \sum_{i=0}^N a_i x(nT - iT)$$

- ▶ Hence the transfer function assumes the form

$$\begin{aligned} \frac{Y(z)}{X(z)} = H(z) &= \sum_{i=0}^N a_i z^{-i} \\ &= \frac{\sum_{i=0}^N a_i z^{N-i}}{z^N} \end{aligned}$$

- ▶ Evidently, *the poles of nonrecursive systems are all located at the origin* of the z plane.

Derivation of Transfer Function from a Network

- ▶ The unit delay, adder, and multiplier are characterized by the equations

$$y(nT) = x(nT - T), \quad y(nT) = \sum_{i=1}^K x_i(nT), \quad y(nT) = mx(nT)$$

Derivation of Transfer Function from a Network

- ▶ The unit delay, adder, and multiplier are characterized by the equations

$$y(nT) = x(nT - T), \quad y(nT) = \sum_{i=1}^K x_i(nT), \quad y(nT) = mx(nT)$$

- ▶ Hence if we apply the z transform, we get

$$Y(z) = z^{-1}X(z), \quad Y(z) = \sum_{i=1}^K X_i(z), \quad Y(z) = mX(z)$$

Derivation of Transfer Function from a Network

- ▶ The unit delay, adder, and multiplier are characterized by the equations

$$y(nT) = x(nT - T), \quad y(nT) = \sum_{i=1}^K x_i(nT), \quad y(nT) = mx(nT)$$

- ▶ Hence if we apply the z transform, we get

$$Y(z) = z^{-1}X(z), \quad Y(z) = \sum_{i=1}^K X_i(z), \quad Y(z) = mX(z)$$

- ▶ By using these relation, $H(z)$ can be obtained directly from a network representation.

Example

Find the transfer function of the system:

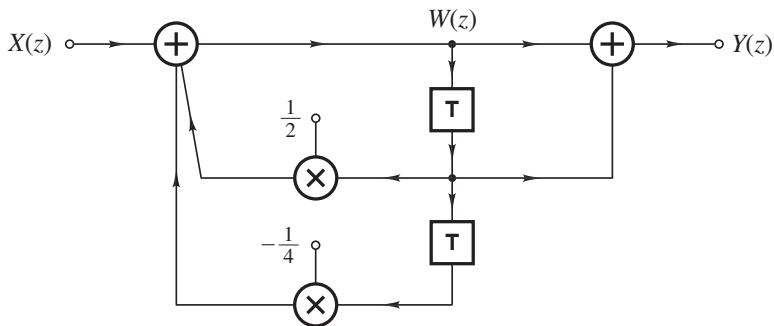

Example *Cont'd*

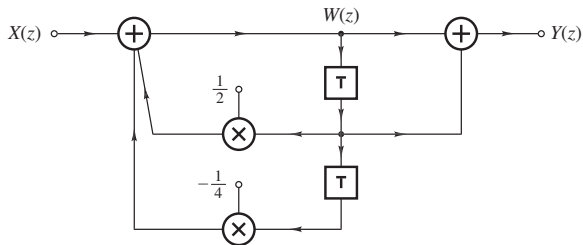

Solution By inspection

$$W(z) = X(z) + \frac{1}{2}z^{-1}W(z) - \frac{1}{4}z^{-2}W(z)$$

and

$$Y(z) = W(z) + z^{-1}W(z)$$

Example *Cont'd*

• • •

$$W(z) = X(z) + \frac{1}{2}z^{-1}W(z) - \frac{1}{4}z^{-2}W(z)$$

and

$$Y(z) = W(z) + z^{-1}W(z)$$

Hence

$$W(z) = \frac{X(z)}{1 - \frac{1}{2}z^{-1} + \frac{1}{4}z^{-2}}, \quad Y(z) = (1 + z^{-1})W(z)$$

If we eliminate $W(z)$ in the right-hand equation, we obtain

$$H(z) = \frac{z(z+1)}{z^2 - \frac{1}{2}z + \frac{1}{4}} \quad \blacksquare$$

Derivation from a State-Space Representation

- ▶ A discrete-time system can be represented by the state-space representation

$$\mathbf{q}(nT + T) = \mathbf{A}\mathbf{q}(nT) + \mathbf{b}x(nT) \quad (\text{A})$$

$$y(nT) = \mathbf{c}^T \mathbf{q}(nT) + dx(nT) \quad (\text{B})$$

Derivation from a State-Space Representation

- ▶ A discrete-time system can be represented by the state-space representation

$$\mathbf{q}(nT + T) = \mathbf{A}\mathbf{q}(nT) + \mathbf{b}x(nT) \quad (\text{A})$$

$$y(nT) = \mathbf{c}^T \mathbf{q}(nT) + dx(nT) \quad (\text{B})$$

- ▶ Applying the z transform to Eq. (A), we get

$$\mathcal{Z}\mathbf{q}(nT + T) = \mathbf{A}\mathcal{Z}\mathbf{q}(nT) + \mathbf{b}\mathcal{Z}x(nT)$$

or

$$z\mathbf{Q}(z) = \mathbf{A}\mathbf{Q}(z) + \mathbf{b}X(z)$$

Derivation from a State-Space Representation

- ▶ A discrete-time system can be represented by the state-space representation

$$\mathbf{q}(nT + T) = \mathbf{A}\mathbf{q}(nT) + \mathbf{b}x(nT) \quad (\text{A})$$

$$y(nT) = \mathbf{c}^T \mathbf{q}(nT) + dx(nT) \quad (\text{B})$$

- ▶ Applying the z transform to Eq. (A), we get

$$\mathcal{Z}\mathbf{q}(nT + T) = \mathbf{A}\mathcal{Z}\mathbf{q}(nT) + \mathbf{b}\mathcal{Z}x(nT)$$

or
$$z\mathbf{Q}(z) = \mathbf{A}\mathbf{Q}(z) + \mathbf{b}X(z)$$



Hence
$$z\mathbf{I}\mathbf{Q}(z) = \mathbf{A}\mathbf{Q}(z) + \mathbf{b}X(z)$$

or
$$\mathbf{Q}(z) = (z\mathbf{I} - \mathbf{A})^{-1}\mathbf{b}X(z) \quad (\text{C})$$

where \mathbf{I} is the identity matrix.

Derivation from a State-Space Representation *Cont'd*

• • •

$$\mathbf{q}(nT + T) = \mathbf{A}\mathbf{q}(nT) + \mathbf{b}x(nT) \quad (\text{A})$$

$$y(nT) = \mathbf{c}^T \mathbf{q}(nT) + dx(nT) \quad (\text{B})$$

or

$$\mathbf{Q}(z) = (z\mathbf{I} - \mathbf{A})^{-1} \mathbf{b}X(z) \quad (\text{C})$$

► Now from Eq. (B)

$$Y(z) = \mathbf{c}^T \mathbf{Q}(z) + dX(z) \quad (\text{D})$$

Derivation from a State-Space Representation *Cont'd*

• • •

$$\mathbf{q}(nT + T) = \mathbf{A}\mathbf{q}(nT) + \mathbf{b}x(nT) \quad (\text{A})$$

$$y(nT) = \mathbf{c}^T \mathbf{q}(nT) + dx(nT) \quad (\text{B})$$

or
$$\mathbf{Q}(z) = (z\mathbf{I} - \mathbf{A})^{-1} \mathbf{b}X(z) \quad (\text{C})$$

► Now from Eq. (B)

$$Y(z) = \mathbf{c}^T \mathbf{Q}(z) + dX(z) \quad (\text{D})$$

► If we now eliminate $\mathbf{Q}(z)$ using Eq. (D), we have

$$H(z) = \frac{Y(z)}{X(z)} = \frac{N(z)}{D(z)} = \mathbf{c}^T (z\mathbf{I} - \mathbf{A})^{-1} \mathbf{b} + d \quad \blacksquare$$

where $N(z)$ and $D(z)$ are polynomials in z .

*This slide concludes the presentation.
Thank you for your attention.*