

Project Questions

INSTRUCTIONS

1. State any assumptions that may be necessary.
2. Show all details of your solution.
3. There are 7 problems of equal weight.

1. The machine readable passports include check digits computed as follows: Each digit of the number (such as the date of birth) is multiplied by the corresponding digit in the sequence 731731731.... These products are then added and the result mod 10 is the check digit. Thus the date November 12, 1945 would be written 451112 and the corresponding check digit is

$$4 \times 7 + 5 \times 3 + 1 \times 1 + 1 \times 7 + 1 \times 3 + 2 \times 1 = 6 \pmod{10}$$

- (a) Why was the sequence 731731731... chosen?
 - (b) Can single digit errors be detected?
 - (c) Can transpositions of adjacent digits be detected?
 - (d) Can erasures be corrected?
2. Consider an $[n, k]$ binary linear code C whose generator matrix G contains no zero column. If all the codewords of C are arranged as rows of a $2^k \times n$ array,
 - a) show that no column of the array contains only zeros.
 - b) show that each column of the array contains 2^{k-1} zeros and 2^{k-1} ones.
 - c) show that the set of all codewords with zeros in a particular location forms a subspace of C . What is the dimension of this subspace?
 - d) show that the set of all codewords with even weight forms a subgroup of Z_2^n .
 3. Let C be a binary linear (n, k, d) code with generator matrix G . We may assume that the first row of G has the form $1 \cdots 1 0 \cdots 0$. Hence G has the form

$$G = \begin{bmatrix} 1 & \cdots & 1 & 0 & \cdots & 0 \\ & & G_1 & & G_2 & \end{bmatrix}.$$

Let d_2 be the minimum distance of the $[n - d, k - 1]$ code with generator matrix G_2 . Show that $d_2 \geq d/2$.

4. Let C be a binary cyclic code. Prove that C contains a codeword of odd weight if and only if C contains the all-ones codeword.
5. Consider the convolutional encoder in Figure 1.
 - a) Find the impulse response for this encoder.
 - b) Find the transfer function matrix for this encoder.
 - c) Use the transfer function matrix to determine the codeword associated with the input sequence $\mathbf{x} = (11101)$.
6. Consider the convolutional encoder in Figure 1.
 - a) Construct a state diagram for this encoder.
 - b) Compute the weight enumerator for the code generated by this encoder.
7. Consider the convolutional encoder in Figure 2. Assume this encoder is used over a binary symmetric channel. Find the maximum-likelihood codeword corresponding to the received sequence $\mathbf{r} = (10, 11, 11, 11, 01, 00)$.

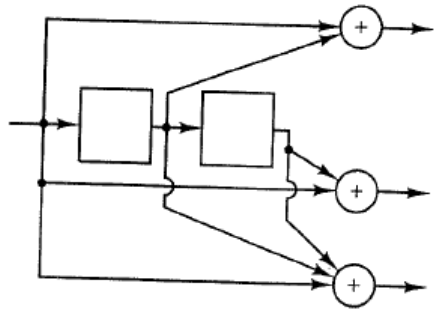

Figure 1

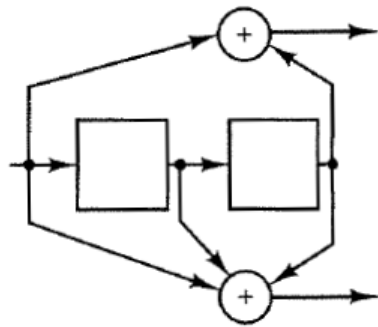

Figure 2