

Operational Amplifiers Part IV of VI Working Your Amplifier Inside the Single-Supply Voltage “Box”

by Bonnie C. Baker

Microchip Technology, Inc. bonnie.baker@microchip.com

It may seem easy enough to transfer classical dual-supply, operational-amplifier circuits directly into a single-supply environment. This is true for a few circuits, but now your amplifier output is swinging much closer to the supply rails than before, and your ground reference has disappeared. Here, we examine standard voltage-feedback amplifier circuits (such as non-inverting gain) inverting gain, difference amplifiers, instrumentation amplifiers, and a photo-sensing configuration. Within these discussions, we will explore the advantages and limitations of working inside the single-supply environment.

Issues to Consider When You Convert from Dual Supply to a Single Supply

You could say that an operational amplifier is an operational amplifier, regardless of the supply voltage that is used. The general characteristics from one device to another are consistent. All voltage-feedback amplifiers have two high-impedance inputs and a low-impedance output. When in a closed-loop circuit, the voltage of the two inputs of the amplifier track each other. The amplifier open-loop gain from input to output is usually above 80 dB or 10,000 V/V. These general characteristics are not the issues that get you into trouble when you convert from dual-supplies to a single-supply. In this article, the voltage of the dual supplies is ± 15 V and the voltage of the single supply is +5V.

You should focus on two performance characteristics when performing this conversion. These two issues are the input-voltage range and output-voltage swing. The input and output characteristics are fully specified in single-supply operational amplifier data sheets. Generally, if you are converting to a single-supply amplifier circuit these specifications, from amplifier to amplifier, are very close. However, if you don't account for these performance limitations, you will drive the input or output of your amplifier well outside the operating ranges. Outside these ranges the “good” and the “best” single-supply amplifiers act the same.

In this discussion, it is presumed that you understand the circuit design topologies of single-supply amplifiers. “Operational Amplifiers Part 1 of 6: What Does “Rail-to-Rail” Input Operation Really Mean?”⁽¹⁾ discusses the details of the topology of the single-supply amplifier input stages. If you read this article, you will find that when common-mode voltage goes beyond the capabilities of the input transistors the output of the amplifier will latch to either rail. “Operational Amplifiers Part 2 of 6: Working with Single-Supply Operational-Amplifier Output Characteristics”⁽²⁾ discusses the details of single-supply amplifier output-stage performance. This article defines two areas of the amplifier output-stage operation. If you drive your amplifier “hard” into either rail (within a few 10s of millivolts), the amplifier will leave its linear region. If you only drive your amplifier a few hundred millivolts from the rails (as defined in the open-loop gain specification), the amplifier will perform in its linear region.

We will concentrate on these two performance characteristics. You will find that this gives you enough guidance to successfully convert all of your amplifier dual power-supply circuits to single supply. And, as stated before, besides these two areas, an amplifier is an amplifier.

The Buffer-Amplifier Configuration

The buffer is the easiest amplifier circuit to transfer from a dual-supply to a single-supply environment. Fig. 1 shows an amplifier configured as a buffer.

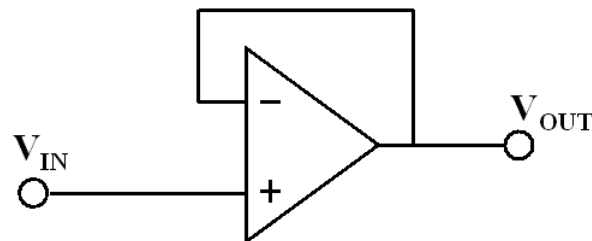

$$V_{OUT} = V_{IN}$$

Fig. 1: Buffer Amplifier Operates With Same Topology For Dual/Single-Supplies

When an amplifier is configured using a single-supply source, there are a few unexpected limitations of the input and output stages. The input stage of single-supply amplifiers can stop the signal from entering the amplifier. If the data sheet of the amplifier does not claim rail-to-rail operation, it most likely will not be a rail-to-rail input amplifier. This limits your input swing. If the input to the amplifier, V_{IN} , goes above the limits of the input transistor, the output travels to the positive rail.

The output stage also limits the performance of this circuit in a single-supply configuration. With dual-supplies, the output stage is able to perform across its full output range without distortion. For instance, if the amplifier (Fig. 1) had a ± 15 V supply and the input, V_{IN} , was 10V, V_{OUT} would be 10V also (assuming no offset errors exist). This conclusion is obvious. However, if you use a (0 V to) +5 V supply on the same circuit, with an input voltage of zero volts the output will not produce the same voltage. The output will ride 10s of millivolts above ground. The actual limit for this value is the low-level, output-voltage swing and dependant on the particular amplifier you are using.

If you are counting on sending a negative voltage through this circuit, it will not work. Again, this may seem obvious. However, you are converting from a dual-supply to a single-supply environment. If the electronics before the amplifier still use a dual supply, this can be a problem.

The phenomena will also happen at the positive, output-voltage rail. If you are using a rail-to-rail input amplifier and you drive the output high, the output will fall short of reaching the supply rail, or +5 V. It will actually fall short by 10s of millivolts below the supply. The amplifier's data sheet calls out this actual limit as the high-level output-voltage swing.

This may not seem like a significant problem unless you are counting on using these extreme voltages in your system. For instance, if your amplifier is driving an ADC that has an input range of 0 to 5 V, several codes on the bottom and top of your digital output word will never appear.

Non-Inverting Configurations With Gain Built-in

The non-inverting configuration is more forgiving than the buffer circuit. With the non-inverting amplifier configuration (Fig. 2.), the gain of the circuit is greater than +1V/V. This circuit takes the voltage applied to V_{IN} and gain it using the resistors in the circuit.

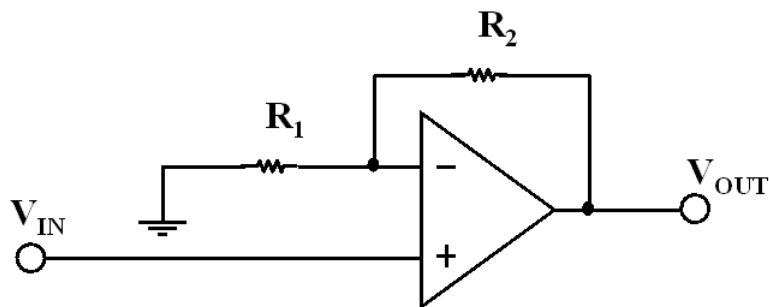

$$V_{OUT} = V_{IN} (1 + R_2/R_1)$$

Fig. 2: Non-Inverting Amplifier Gained By Equation $(1 + R_2 / R_1)$

This circuit is not hard to convert between a dual- and single-supply environment. The input stage limitations do not come into play as much as they did with the buffer circuit. Most single-supply amplifiers have an input, common-mode-range to ground. This amplifier circuit will gain any signal on the input, V_{IN} , to a higher value. It is probable that the output stage will limit the signal on the positive supply rail before the input stage can reach any internal limits.

Photo-Sensing Problems

The transimpedance amplifier used for photo-sensing applications is a little more difficult to convert from dual- to single-supply environments. A primary issue is to correctly bias the photosensor across the input terminals. Fig. 3 illustrates the proper connection.

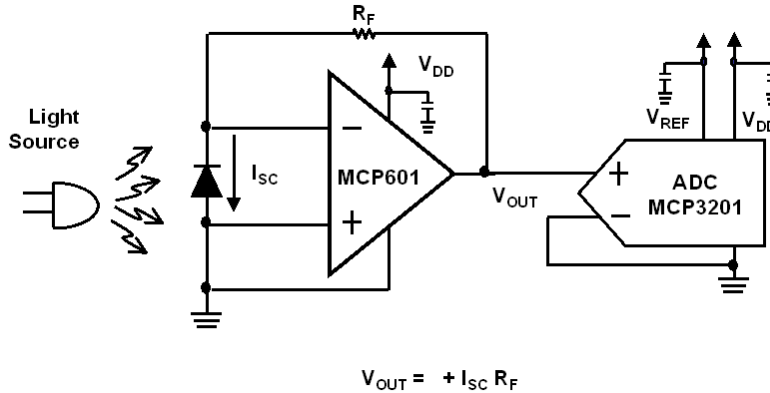

Fig. 3: Grounding Anode Of Photo-Sensor, Attaching Cathode To R_F Allows Sensor Current Flow Through R_F , Creating Positive Voltage At V_{OUT} . Reversing Polarity Of Photo-Sensor Reverses Sensor Current Grounding Output

In this configuration (Fig. 3), the current from the photo-diode during excitation by light will change the output of the amplifier in a positive direction. This appears to work well except for the fact that the amplifier's output is unable to swing all the way down to ground. Consequently, less illumination from the light source will not be detected.

Fig. 4 solves this problem. The output is raised by 300 mV (from ground) using the level-shift network of R_1 , R_2 , and A_2 ensuring that the amplifier operates in its linear region.

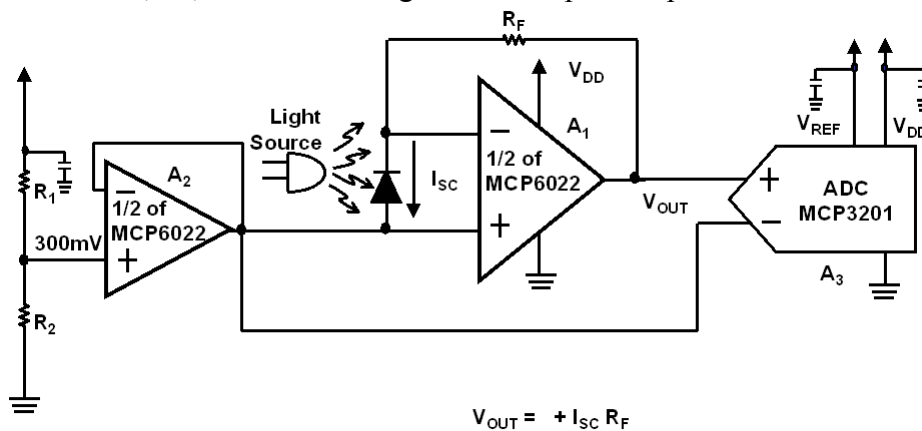

Fig. 4: $R_1/R_2/V_{DD}$ Form Voltage Divider With 300 mV Output. A_2 Isolates R_1/R_2 Impedance of R_1/R_2 Connecting Voltage To Photo-Sensor Anode, Also Shifting Output Voltage Of TIA

The conditions of the open-loop gain specification of the MCP6022 are “ $V_{OUT} = V_{SS} + 300 \text{ mV}$ and $V_{DD} - 300 \text{ mV}$.” This circuit creates a 300 mV level shift of the signal so that the amplifier, A_1 , remains in its linear region. The selection of A_2 is critical. A_2 must

be able to supply current to the photo-sensing circuit in a timely manner. Consequently, A_2 must be as fast or faster than A_1 . Dual amplifiers work well with these requirements. A precision voltage reference (replacing V_{DD}) at the top of R_1 will add stability and reduce noise.

The Inverting Configuration Will Surprise You

The inverting-amplifier configuration (Fig. 5) will only work in a single-supply circuit if you have a voltage reference. You can imagine that by connecting the voltage reference node, V_{SHIFT} , to ground, the circuit would only work if the input signal were negative.

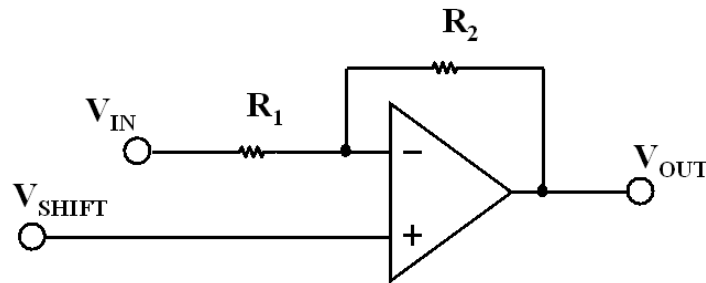

$$V_{OUT} = V_{SHIFT} (1 + R_2/R_1) - V_{IN} (R_2/R_1)$$

Fig. 5: Single-Supply Circuit Needs Ref. Voltage To Work. Output Tries To Go Below Ground With Positive Input, V_{SHIFT} Grounded. Works Well With Negative Input Voltage. But Where Would That Come From In Single-Supply Circuit?

Fig. 6 shows one example of a voltage-reference circuit.

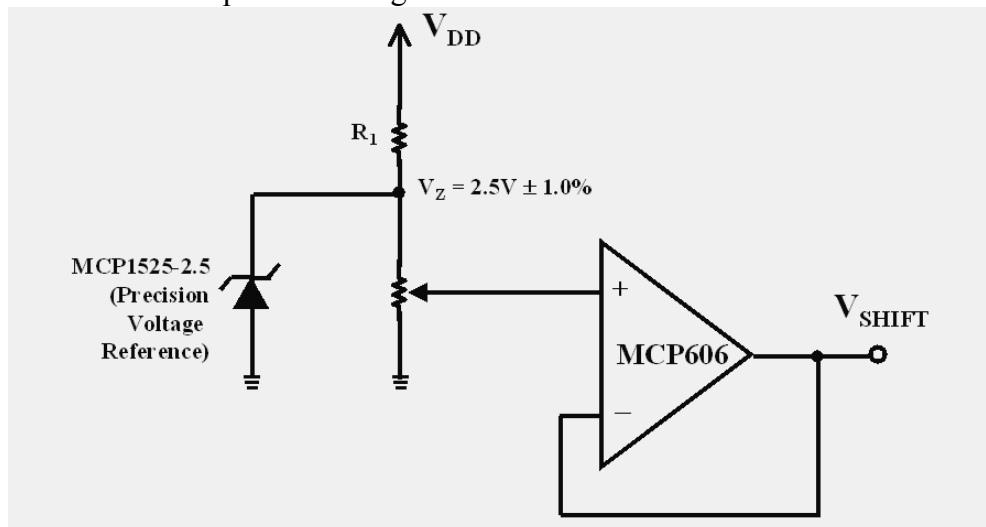

Fig. 6: Type Of Voltage Reference To Drive V_{SHIFT} (Fig. 5) Input Level Shifts Output Of Amplifier Into Linear Region. Set V_{SHIFT} Around Center Of Input Range

The Difference Amplifier

Fig. 7 illustrates an implementation of the difference-amplifier function. The dc transfer function of this circuit is equal to:

$$V_{OUT} = V_1 R_4(R_1+R_2) / ((R_3+R_4)R_1) - V_2(R_2/R_1) + V_{SHIFT} R_3 (R_1+R_2) / ((R_3+R_4)R_1)$$

If R_1/R_2 is equal to R_3/R_4 , the closed-loop output of this circuit equals:

$$V_{OUT} = (V_1 - V_2)(R_2/R_1) + V_{SHIFT}$$

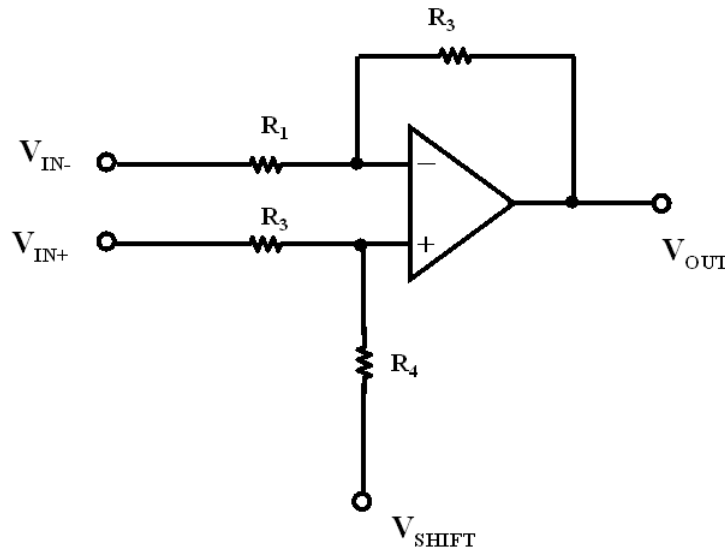

$$V_{OUT} = (V_1 - V_2)(R_2/R_1) + V_{SHIFT}$$

(if $R_1 = R_2$ and $R_3 = R_4$)

Fig. 7: Difference Amplifier Operates Best In Dual-Supply: Ground V_{SHIFT} . With Single-Supply Connect V_{SHIFT} To $\frac{1}{2} V_{DD}$

In this circuit, the maximum allowable voltage of the amplifier's inputs limit the input common-mode range. It is possible to have input voltages at V_1 and V_2 that exceed the power-supply voltages. The gain on both input signals is equal and the resistor configuration also subtracts the common-mode voltage of both. In addition, by setting the two resistor ratios to be greater than one, you can easily implement a gain larger than one.

In a single-supply environment, a voltage reference (V_{SHIFT}) can center the output signal between ground and the power supply. Otherwise, it is possible to drive the output beyond the ground or V_{DD} rail. The purpose and effects of this reference voltage are to shift the output signal into the linear region of the amplifier.

Fig. 8 illustrates two possible circuits for the voltage, V_{SHIFT} .

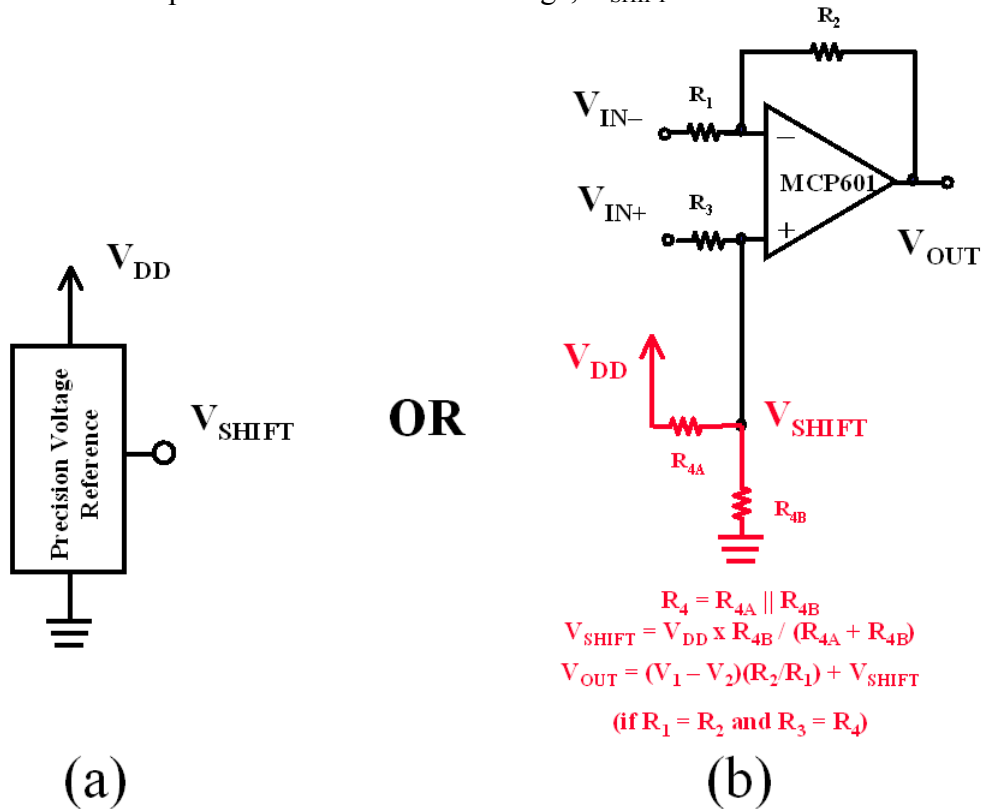

Fig. 8: Precision Voltage Reference (a), Or Resistor Divider (b) Between V_{DD} /Ground Used To Generate V_{SHIFT} (Fig. 7). Used In Single-Supply Difference, Three-Amp. Instrumentation, And Two-Amp Instrumentation Amplifiers

The precision, voltage-reference device in Fig. 8(a) is a suitable high-precision solution for your single-supply circuits. This voltage reference will give you accurate, dc results at room and over temperature. Fig. 8(b) illustrates an alternative solution, splitting the resistor, R_4 (Fig. 7) between V_{DD} and ground to provide a voltage for V_{SHIFT} . Fig. 8 summarizes the governing equations for the voltage of V_{SHIFT} and gain of the difference amplifier. The accuracy of this circuit depends on the resistor matching and V_{DD} stability.

The Three-Amp Instrumentation Amplifier

The most versatile instrumentation amplifier configuration uses three operational amplifiers in its implementation. This instrumentation amplifier is easy to understand because each of the three operational amplifiers serves a specific function. With this circuit configuration (Fig. 9), two of the three operational amplifiers (A_1 and A_2) gain the two input signals. The third amplifier, A_3 , subtracts the two gained input signals, thereby providing a single-ended output. The transfer function of the circuit is equal to:

$$V_{OUT} = (V_{IN+} - V_{IN-})(1 + 2R_F/R_G) (R_2/R_1)$$

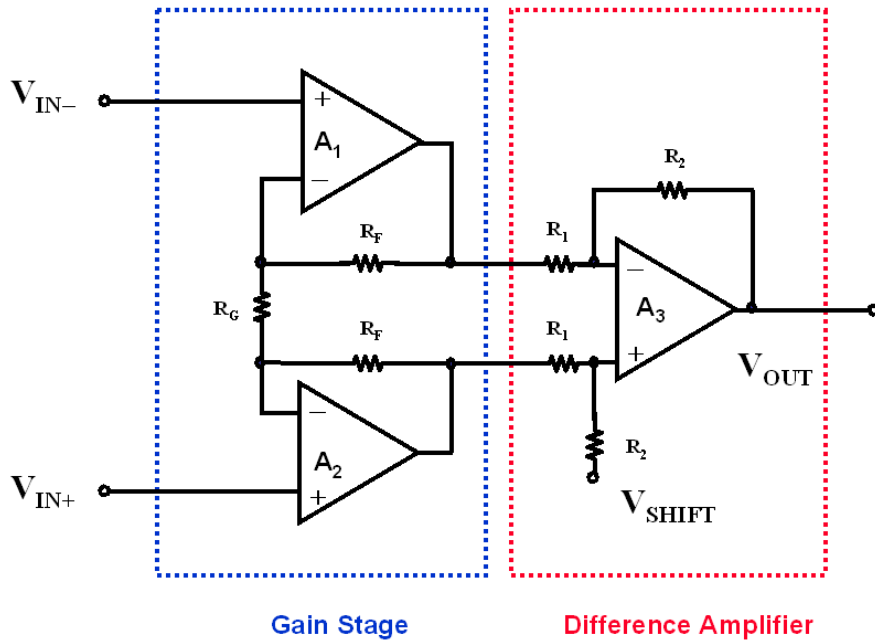

Fig. 9: Three-Amp Instrumentation Amplifier Has Two Fundamental Stages, Gaining Input Signals And Difference Amplifying Them

In single-supply applications, the circuits in Fig. 8 generate the center reference, V_{SHIFT} .

The Two-Amp Instrumentation Amplifier

The design shown in Fig. 10 uses two operational amplifiers. This design configuration is typically called the two op-amp instrumentation amplifier.

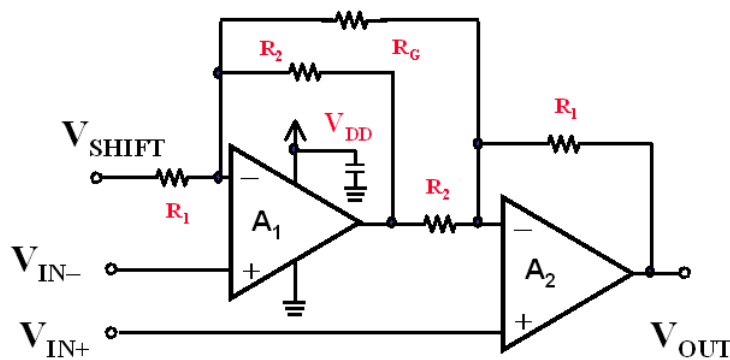

Fig. 10: Dual- Or Single-Supply Can Power Two Amp-Instrumentation Amplifier. Single-Supply Circuits Require Center-Supply Reference, V_{SHIFT}

Discrete designs use dual amplifiers for good matching of bandwidth and performance over temperature. This instrumentation amplifier uses the high impedance of the non-

inverting input of the operational amplifiers, thereby significantly reducing source impedance mismatch problems at dc. The transfer function of this circuit is equal to:

$$V_{OUT} = (V_{IN+} - V_{IN-})(1 + R_1/R_2 + 2R_1/R_G) + V_{SHIFT}$$

If the application is in a single-supply environment, this circuit will typically require a reference that is half of the way between the power-supply voltages. In Fig. 10, V_{SHIFT} serves that function. This circuit does not allow for zero-volt, common-mode, input voltages in single-supply systems.

The center-supply reference, V_{SHIFT} , is implemented using circuits in Fig. 8.

Conclusions

The task of transferring your dual-supply amplifier circuits to single-supply environments is straightforward. During the conversion, pay attention to input common-mode range and output-swing specification violations. If any violations of the single-supply amplifier's input or output stage result from the new power supplies, the addition of a voltage reference can eliminate these violations, making the circuit usable.

References:

- (1) "Operational Amplifiers Part 1 of 6": *What Does "Rail-to-Rail" Input Operation Really Mean?*; Baker, Bonnie, analogZONE, March 22, 2004
<http://www.analogZONE.com/acqt0322.pdf>
- (2) "Operational Amplifiers Part 2 of 6": *Working with Single-Supply Operational-Amplifier Output Characteristics*; Baker, Bonnie, analogZONE, May 3, 2004
<http://www.analogZONE.com/acqt0503.pdf>
- (3) "Operational Amplifiers Part 3 of 6": *How Do You Choose the Right Amplifier for Your Low-Pass Filter?*; Baker, Bonnie June 14, 2004
<http://www.analogZONE.com/acqt0614>

